

Town of Shellbrook

Bylaw No. 2015-08

A Bylaw of the Town of Shellbrook to provide for the regulations
and control of the Public Cemetery

The Mayor and Council of the Town of Shellbrook, in the Province of Saskatchewan, enacts as follows:

1. This Bylaw may be cited as “The Cemetery Bylaw”.
2. A. Administrator:
Means the Town Administrator of the Town of Shellbrook
- B. Cemetery:
Cemetery means land “within or outside the Town of Shellbrook” set apart for or used as a place of interment of the dead or in which human bodies may be buried.
Shellbrook Cemetery shall be described as follows:
A portion of the West Half of Section Eighteen (18), Township Forty-Nine (49), Range Three (3), West of the Third (3rd) Meridian.
- C. Cemetery Committee:
Shall consist of the Public Works Committee duly appointed by council.
- D. Council:
Means the Council of the Town of Shellbrook.
- E. Licensee:
A person or persons who obtains a permit/licence to use a grave or graves in the Shellbrook Cemetery.
- F. Marker:
The term “marker” shall mean a memorial of granite, hard marble of bronze flush with the ground.
- G. Monument:
The term “monument” shall include a tombstone or memorial of granite, hard marble, or other adamant material which shall extend above the surface of the ground.
- H. Plot/Grave:
Grave means a subdivision of the land for the purpose of a single burial in the Cemetery as shown in the Town Cemetery plan.
- I. Double Plot/Double Grave:
Means an area large enough for two or more graves.
- J. Public Works Director:
Means the Director of the Public Works Department of the Town of Shellbrook, or any person

acting under his instructions, or the other person designated by the Town Council.

K. Section:

Means an area of more than one double plot.

L. Veteran:

- A Person who has given wartime service to Canada, NATO or The United Nations, or one of Canada's allies.
- A person who has served in the merchant navy.
- A person who has given peacekeeping services under programs which were coordinated by Canada, The United Nations or NATO.
- Any person who has been a member of Canada's regular armed forces.
- All Canadian reserve personnel who have served not less than six months service in active wartime or peace keeping duties.

3. General Rules:

- A. Employees of the Cemetery are not permitted to do any work for lot owners except upon order of the Cemetery Committee but are required to be civil and courteous to all visitors.
- B. All persons, while in the Cemetery, shall conduct themselves in a quiet and orderly manner.
- C. Persons within the Cemetery shall use only the avenues, roads, walks, and alleys and no one is permitted to walk upon or across graves. The Town of Shellbrook expressly disclaims liability for any injuries sustained by anyone violating this rule.
- D. Persons visiting the Cemetery or attending funerals are strictly prohibited from picking flowers, wild or cultivated, breaking or injuring any tree, shrub, or plant, or from writing upon, defacing or injuring any memorial, fence or other structure within the Cemetery grounds.
- E. Motor cars and vehicles in the Cemetery shall travel only on the roadways provided for that purpose and shall not travel at a greater rate of speed than 10 miles per hour.
- F. Fences, borders, railing, curbs, coping, trellises, walls, hedges, or grave covering, or curbs shall not be permitted in the cemetery, however, those existing at the time of the passage of this bylaw shall be permitted to remain until such a time as they require maintenance.
- G. Notwithstanding 3.F, grave covers may, with written permission of Council, be permitted on graves where it is required to match a spouse's existing grave cover on an adjacent grave. In situations of this nature, the graves must abut one another.
- H. Development of the new section of the Cemetery being part of the NW 18-49-03-W3rd may be undertaken as required under the direction of the Cemetery Committee.
- I. The Town or any official thereof shall not be responsible for any mistakes resulting from lack of precise or proper instructions regarding the grave space on a lot or plot where an interment is to be or has been made.

4. Section, Plot and Grave:

- A. The Administrator or his or her appointee shall issue all licenses to use graves in the cemetery and shall receive all monies resulting from the sale of such grave.
- B. The Administrator shall keep a correct account of all monies received therefrom and of all cemetery, with the name and description of the licensee thereof and of every transfer and all other books necessary to keep a complete record of all businesses transacted by him in connection with the cemetery.
- C. The fee for purchase of lots and perpetual care are is set out in Schedule "A" attached to this bylaw. The said schedule may be amended from time to time in a resolution of council. The perpetual care fee will be placed into a reserve and used for future maintenance.
- D. Cemetery plots shall not be resold or transferred by the licensee, but may be transferred back to the Town of Shellbrook. In case of a transfer to the Town, the Town will refund to the licensee, all monies paid by him, less a transfer fee of \$15.00.
- E. No grave shall be used for any other purpose than for burial of the human dead.
- F. The Cemetery Committee shall take all reasonable precautions to protect licensees and the property rights of licensees within the cemetery for loss or damage; but the committee distinctly disclaims all responsibility for a loss or damage from causes from beyond its' reasonable control, and especially from damage caused by the elements, an act of God, common enemies, thieves, vandals, accidents, military or civil authority.
- G. The Cemetery Committee shall designate a specific area of the cemetery for the burial of Veterans and their spouses. Such area shall be set out in the Schedule "B" to this Bylaw.

5. Duties of Public Work Director:

- A. It shall be the duty of the Director or Cemetery Caretaker to determine the location of grave lots, and shall stake a grave lot, or grave lots out before the digging of a grave is undertaken.
- B. It shall be a duty of the Director to maintain the roads leading to and within the cemetery in acceptable conditions.
- C. It shall be the duty of the Director to supervise the digging and filling of the graves to assure other grave sites are not disturbed.

6. Interments and Disinterments:

- A. No interment shall be made in the cemetery until the provision of the Public Health Act and the Vital Statistics Act of the Province of Saskatchewan have been complied with, and with any regulations issued thereunder and until it also shall have complied with the provisions of this bylaw.
- B. Payment of any and all indebtedness due to the Cemetery must be made before any interment.

- C. No interment of two or more bodies shall be made in one grave except in the case of a mother and a child or two infants buried in one casket.
 - D. No grave shall be less than six (6) feet in depth from the surface of the surrounding ground except in case of cremains which shall be buried a minimum of three (3) feet in depth.
 - E. Whenever a selection, plot or grave is held jointly by two or more parties, authority for interment in such selection, plot or grave or any part thereof will be accepted by the Town of Shellbrook from any one of the said parties or their executors or agents.
 - F. No interments shall be permitted in the Cemetery unless a proper burial permit is produced by the parties or their executors or agents.
 - G. Graves shall be opened and interments made only by persons approved in writing by the Town of Shellbrook and under directions of the Cemetery Committee and no person or persons, without said approval of the Town of Shellbrook, shall open any grave for the purpose of interring or removing a body.
 - H. No person shall disinter or remove a body from any grave with out first producing a written order from the licensee of such grave and a permit for such disinterment or removal from Provincial Medical Health Officer. Additional notarized consents will also be required indicating agreement of other family members affected.
 - I. By the order of the Cemetery Committee “graves” in the Cemetery shall be supplied without charge for the burial of indigent persons.
 - J. All caskets shall be placed in burial vaults constructed of fiberglass, plastic, or other similar rigid, non-biodegradable material, unless the casket is constructed of galvanized metal, fiberglass or other non-biodegradable material, in which case no burial vault will be required.
 - K. All graves shall be backfilled in such a manner as to achieve a rate of compaction in the entire backfill at least equal to that of the surrounding natural ground.
7. Cremains:
- A. Graves in the Cemetery may be used for the interment of cremated remains.
 - B. All interments must be registered in the office of the Administrator.
 - C. Not more than four (4) cremains shall be interred in one plot unless written approval is obtained from council. Only two cremains shall be interred where a casket already resides.
 - D. Cremains must be enclosed in a container sealed securely, dry and of sufficient strength to permit interment with the container remaining intact.
 - E. Cremains will be placed down the center of the plot starting at the head of the grave site.
8. Care of Graves:
- A. To obtain the best landscape effects, it is essential that the Cemetery Committee shall assume

the general care of the entire Cemetery. The licensee of graves shall observe all rules and regulations passed from time to time by council for keeping the graves in order.

- B. Fences, borders, railing, curbs, walls, coping, hedges, trellises, or grave covers in existence before the passing of this bylaw will be removed free of charge by the Town upon request in writing by the licensee. Leveling of the ground and the seeding of grass will be carried out by the Town at no cost to the licensee.
- C. Any fences, borders, railing, curbs, walls, copings, hedges, trellises, grave covers or any other bounding or enclosing material erected before the passing of this bylaw may be removed by the Town for reason of neglect of age if it becomes in a state of disrepair and the licensee neglects or refuses to repair or remove the same within thirty (30) days after a notice in writing to do so has been forwarded to him at his last known address, as provided in section eleven (11), subsection (D) of the bylaw.
- D. The Cemetery employees shall have authority to remove all floral designs, flowers, weeds, trees, shrubs, plants, or herbage of any kind from the Cemetery as soon as, in the judgment of the Cemetery committee, they become unsightly, dangerous, detrimental or diseased.
- D. The Cemetery Committee reserves the right to prevent the removal of any flowers, floral designs, trees, shrubs, plants, or herbage of any kind.

9. Plants and Shrubs:

The Cemetery Committee shall undertake to maintain as may be practicable, the planting of trees and shrubs to preserve and maintain landscape features.

10. Monuments and Markers:

- A. All monuments and markers shall be manufactured of granite, hard marble, bronze or other adamant material.
- B. All monuments and markers must be set in a line designated by the Cemetery Committee.
- C. Only ground level markers will be permitted in the new area of the Cemetery described in Section 3.H. of this bylaw.
- D. Each monument and marker shall be constructed of or set on a concrete, granite, or marble foundation of a minimum thickness of 4" (inches). The upper surface of each foundation shall be to ground level and in each case the foundation shall project 4" on all sides of the base of the monument, to be erected thereon. Each foundation shall be constructed by workmen who have received written approval from the Town of Shellbrook or the Cemetery Committee. The cost thereof shall be the responsibility of the person ordering the work done.
- E. All Monuments and Markers shall be set or erected on the head of the grave. In no case will they be permitted at the foot of the grave.
- F. Single Grave Monuments:
The top part shall not exceed 24" wide, 24" thick and 8" high and the base shall not exceed 30"

wide, 30" thick and 6" high. In the case of the burial of more than one person or cremains in a single grave the top part shall not exceed 30" wide, 24" thick and 8" high. The base in such cases shall not exceed 36" wide, 30" thick and 6" high.

G. Two Grave Monuments:

The top part shall not exceed 30" wide, 24" thick and 8" high and the base shall not exceed 36" wide, 30" thick and 6" high.

H. Three Grave Monuments:

The top part shall not exceed 36" wide, 24" thick and 8" high, and the base shall not exceed 42" wide, 30" thick and 6" high.

I. Notwithstanding paragraphs F, G, and H above, any monument may be up to 14" in height if there is no base protruding above ground level.

J. Monuments which do not conform to the requirements set out in Sections

10. F, G, H, and I, may be installed in the cemetery, providing the proposal has received the written permission of Council, where it is required to match a family member's existing monument on an adjacent grave. In situations of this nature, the graves must abut one another.

K. The Town will not accept responsibility for any damage to monuments or markers.

L. All owners of monuments or markers shall be encouraged to carry personal property insurance on their monuments and/or markers.

M. Anyone wishing to construct a marker cover, etc. shall obtain a permit from the Town prior to doing so. All applications for the said permit shall be in the form set out in Schedule "C" to this bylaw.

11. Monuments in Disrepair:

A. Should any tombstone, monument or other structure placed or arranged in the Cemetery be in a state of disrepair, the Town may have the said tombstone, monument or other structure removed from the cemetery if the said licensee does not have the same repaired in accordance with said notice.

B. The Public Works Director shall, from time to time, report to the Town Administrator and to the owners on the condition of any monument which is out of repair and it shall be the duty of the owner of such monument to repair same without delay, to the satisfaction of the Public Works Director.

C. Whenever any owner of a tombstone, monument or other structure neglects to make the required repairs or alterations after being given notice by the public works director to do so, the Director shall allow a period of two (2) months to elapse after the giving of the notice and shall then have power to remove or to repair it and charge the cost thereof to the owner and the cost maybe recovered as a debt due by the owner, to the Town.

D. All notice required to be given to licensees of grave lots or owners of monuments or other parties by this bylaw may be delivered in writing by the Town Administrator or in writing

mailed postage paid to the last known address of such licensee or owner or other party and proof of such notice having been mailed, properly addressed and prepaid, or delivered shall be sufficient proof that such notice has been given.

12. Enforcement of Rules:

The Cemetery Committee is hereby empowered to enforce all rules and regulations and to exclude from the Cemetery, any person violating same and to remove any monument or marker installed contrary to this bylaw. The Cemetery Committee shall have charge of the grounds and buildings including the conduct of funerals, traffic, employees, licensees and visitors and at all times, shall have supervision and control of all persons in the Cemetery.

13. Penalty:

Any person guilty of an infraction of this bylaw or any part thereof, shall be liable on summary conviction to the penalties prescribed by the General Penalty Bylaw of the Town of Shellbrook.

14. Repeal Bylaws:

Bylaw No. 14-2010 is hereby repealed.

Read three (3) times by unanimous consent of council this 22nd day of June 2015.

SEAL

TOWN OF SHELLBROOK

Mayor

Administrator

Read a third time and adopted
this ____ day of _____

Kelly Hoare

Schedule "A"

Bylaw No. 2015-08

A schedule to establish the fees to be charged in regards to the Shellbrook Cemetery

1. Fees for digging graves:

This fee includes both opening and closing a grave.

Single grave for traditional casket type burial

\$400.00 - summer

\$500.00 - winter

Additional \$200 on weekends and holidays.

Single grave for burial of cremains

\$150.00 - summer

\$200.00 - winter

Additional \$100 on weekends and holidays.

Summer being May 1st to November 15th of each year.

Winter being November 16th to April 30th of each year.

2. Fees for the purchase of a license to use a plot:

Single plot - \$200.00

3(a) Fees for the purchase of a license to use a niche in the Columbarium:

Per Niche - \$450.00

3(b) Opening and closing of columbarium \$50.00

4. Permit to install a marker or monument pursuant to section 10. M. of this Bylaw

Permit \$ 50.00

5. Perpetual Care fee – to be placed in a reserve for future maintenance of the cemetery

Per single grave site - \$400.00

Schedule “B”

Bylaw No. 2015-08

A schedule to establish a Veterans Section
in the Shellbrook Cemetery

The Veterans Section shall include the following plots:

486-1	552-11	577-21
486-2	552-12	577-22
486-3	552-13	577-23
486-4	552-14	577-24
486-5	552-15	577-25
487-6	553-16	578-26
487-7	553-17	578-27
487-8	553-18	578-28
487-9	553-19	578-29
487-10	553-20	578-30

Schedule "C"
Bylaw No. 2015-08

A schedule to establish a permit to construct a marker cover, etc. in the Shellbrook Cemetery

Permit to construct a grave marker in the Shellbrook Cemetery

Contractor: _____

Contractor Phone: 1-(306)-_____ - _____

Contractor Address: _____

Contact Name: _____
 (Person Hiring Contractor)

Contact's Phone: 1-(306)-_____ - _____

Contact's Address: _____

Name of Interred: _____

Date of Interment: _____

Date to set marker: _____

Type of material: _____
 (eg. granite, marble)

Dimensions of Marker

- A _____
- B _____
- C _____
- D _____
- E _____
- F _____
- G _____
- H _____

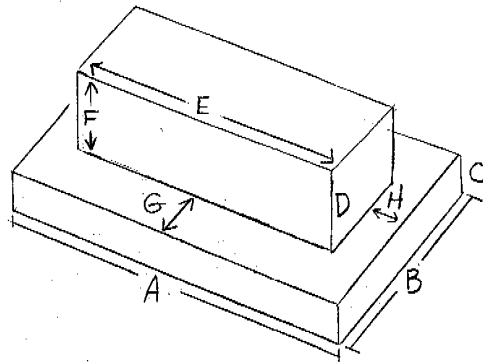

For Reference, from Bylaw 09-2004, Sec. 10 – Monuments and Markers, F to I:

Single Grave (1) Monument	Single Grave (1+) Monument	Two Grave Monument	Three Grave Monument
A - 30	A - 36	A - 36	A - 42
B - 30	B - 30	B - 30	B - 30
C - 6	C - 6	C - 6	C - 6
D - 24	D - 24	D - 24	D - 24
E - 24	E - 30	E - 30	E - 36
F - 8	F - 8	F - 8	F - 8
G - 5	G - 5	G - 5	G - 5
H - 6	H - 6	H - 6	H - 6

